

Fast neutron-induced Fission @ ν ELBE

1. Motivation
2. The neutron time-of-flight facility ν ELBE
3. Cross section and neutron scattering corrections for $^{242}\text{Pu}(n,f)$



HZDR

HELMHOLTZ
ZENTRUM DRESDEN
ROSSENDORF

The problem with the high-level radioactive waste

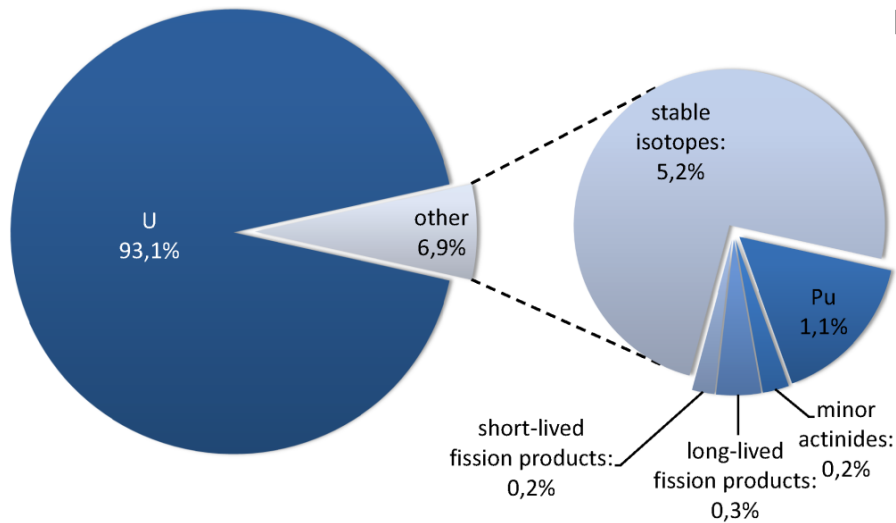

Long-lived radioisotopes causing the main part of the long-term radiotoxicity

→ **Final disposal needed for at least 500.000 years**

→ **Transmutation** can reduce the final disposal time by **several** orders of magnitude

→ ^{242}Pu has the **longest half-life** of all Pu-isotopes (apart from ^{244}Pu , whose contribution could be neglected)

→ **Accurate nuclear data is essential for the development of future transmutation technologies**

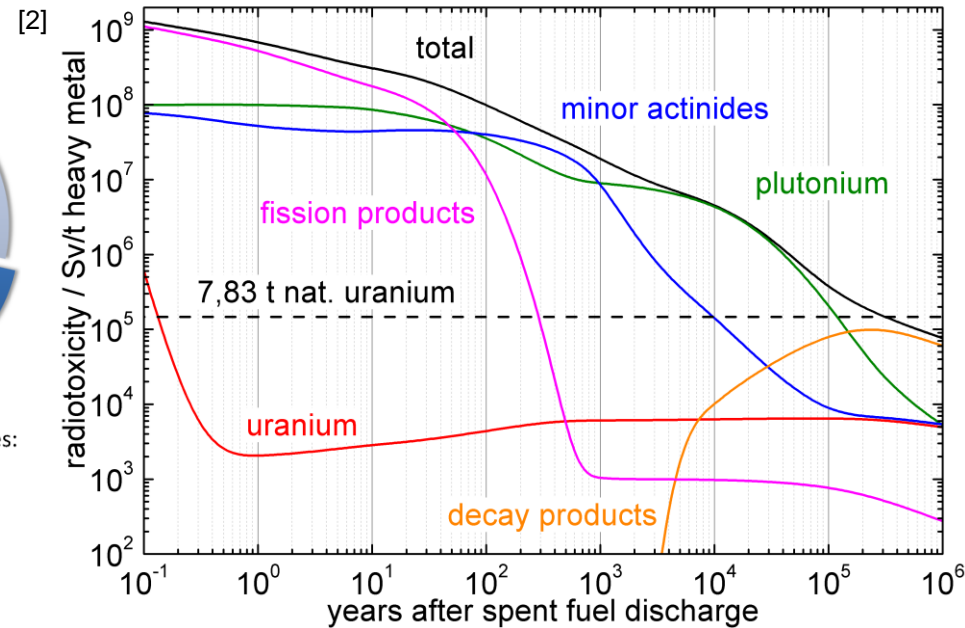

[1] A. Schwenk-Ferrero. German Spent Nuclear Fuel Legacy: Characteristics and High-Level Waste Management Issues. *Science and Technology of Nuclear Installations* **2013**, 1-11 (2013)

[2] Nucleonica webKORIGEN. European Atomic Energy Community, Institute for Transuranium Elements (ITU)

<http://www.nucleonica.net>

The problem with the high-level radioactive waste

[1]

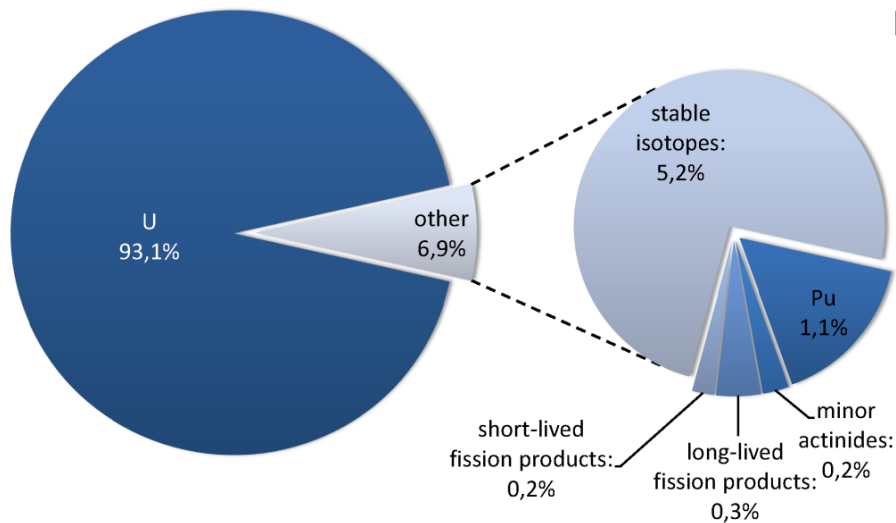

[2]

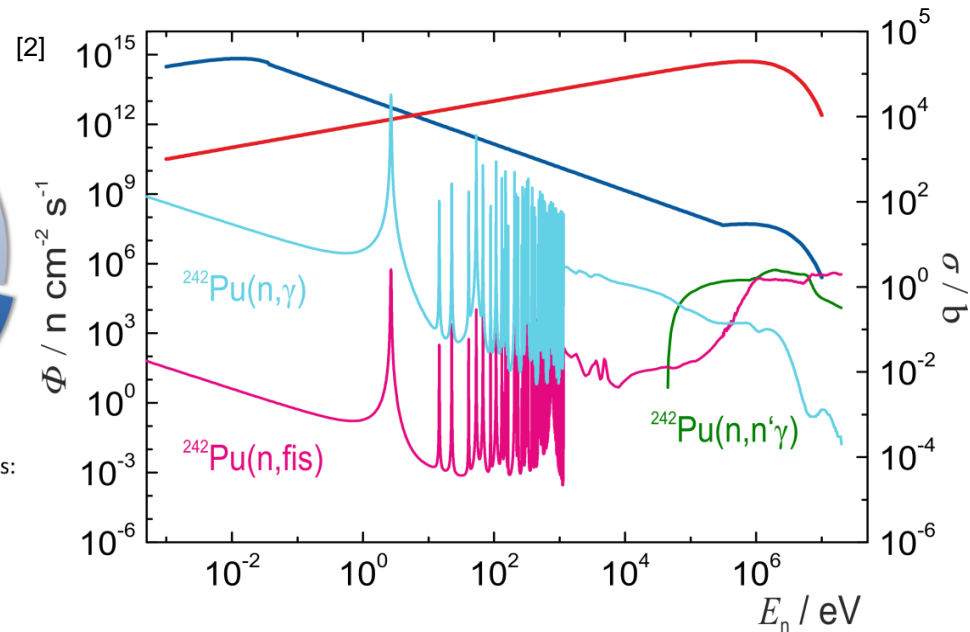

Long-lived radioisotopes causing the main part of the long-term radiotoxicity

➔ **Final disposal needed for at least 500.000 years**

➔ **Transmutation** can reduce the final disposal time by **several** orders of magnitude

➔ ^{242}Pu has the **longest half-life** of all Pu-isotopes (apart from ^{244}Pu , whose contribution could be neglected)

➔ **Accurate nuclear data is essential for the development of future transmutation technologies**

[1] A. Schwenk-Ferrero. German Spent Nuclear Fuel Legacy: Characteristics and High-Level Waste Management Issues. *Science and Technology of Nuclear Installations* **2013**, 1-11 (2013)

[2] Nucleonica webKORIGEN. European Atomic Energy Community, Institute for Transuranium Elements (ITU)

<http://www.nucleonica.net>

Selected EXFOR data of $^{242}\text{Pu}(n,f)$

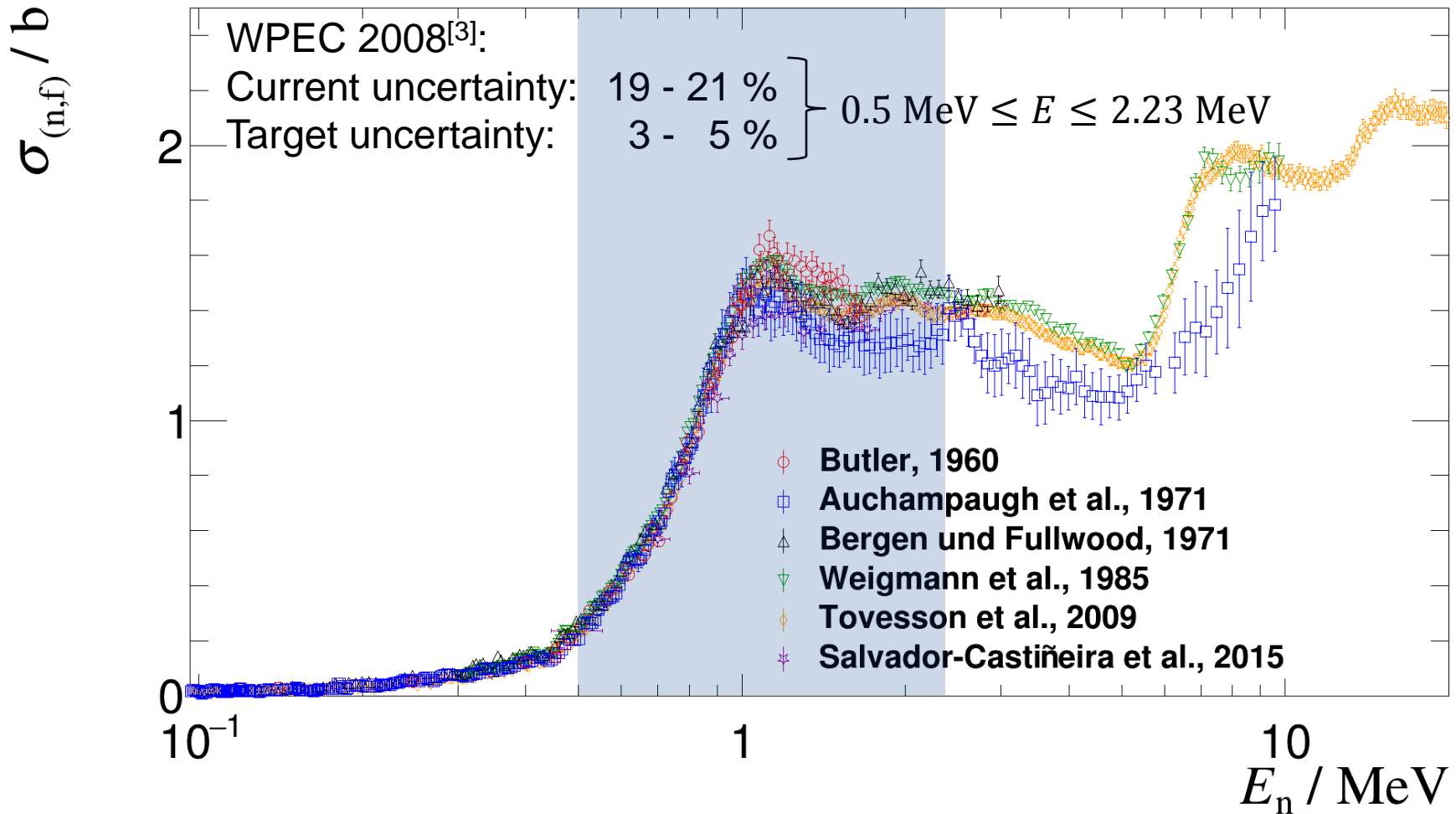

[3] Uncertainty and Target Accuracy Assessment for Innovative Systems Using Recent Covariance Data Evaluations
 Technical Report, Working Party in International Evaluation Co-Operation, OECD / NEA (2008)

ω ELBE – The neutron time-of-flight facility @ ELBE

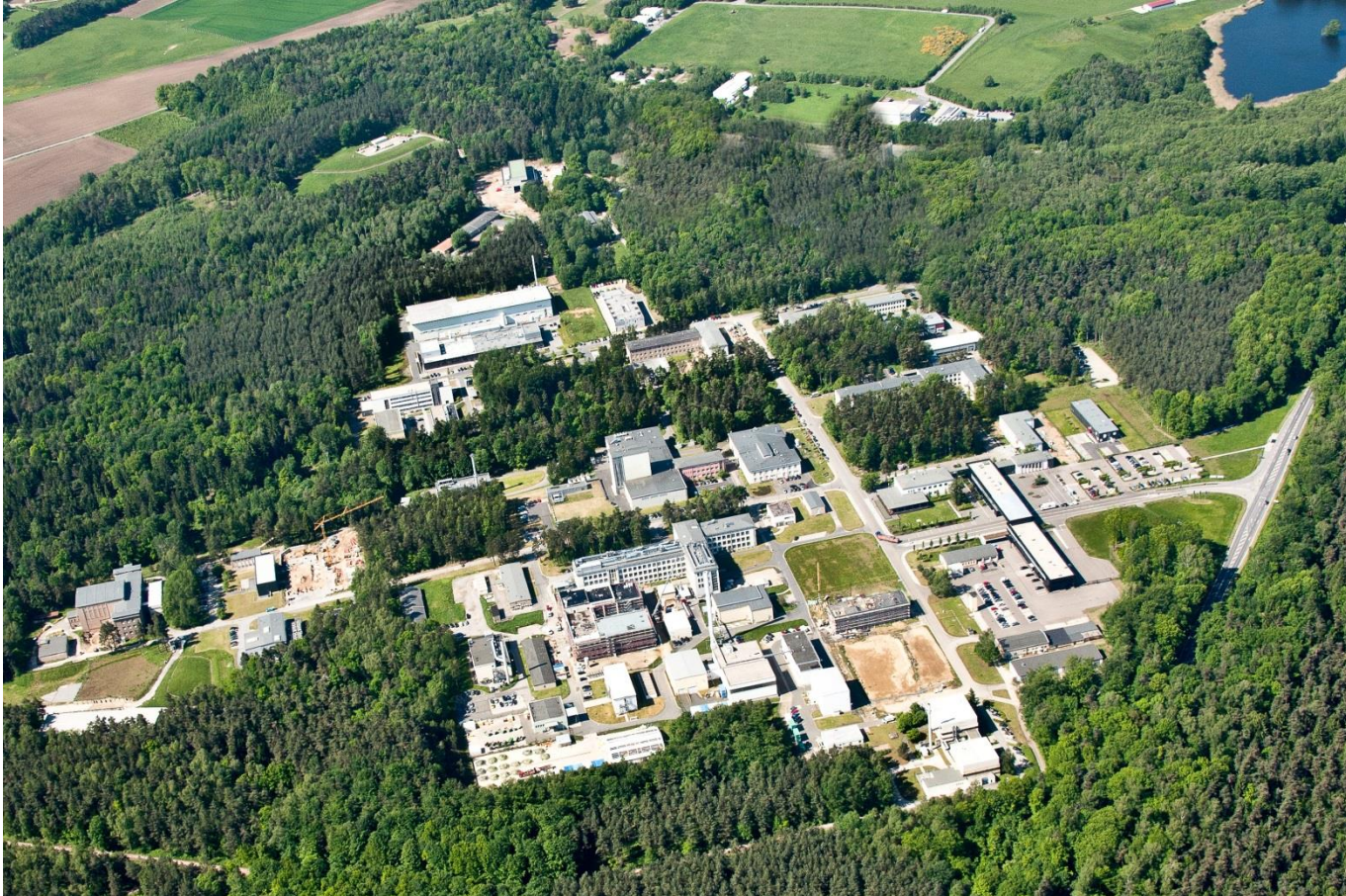

Nuclear data measurements @ ν ELBE

Characteristic parameters:

- repetition rate: 101, 203 & 406 kHz
- flight path 5 – 11 m
- source strength: ca. $1.6 \cdot 10^{11}$ n/s
- intensity @ target: ca. $2.5 \cdot 10^4$ n/s
- energy range: 10 keV – 20 MeV
- energy resolution : < 1 %

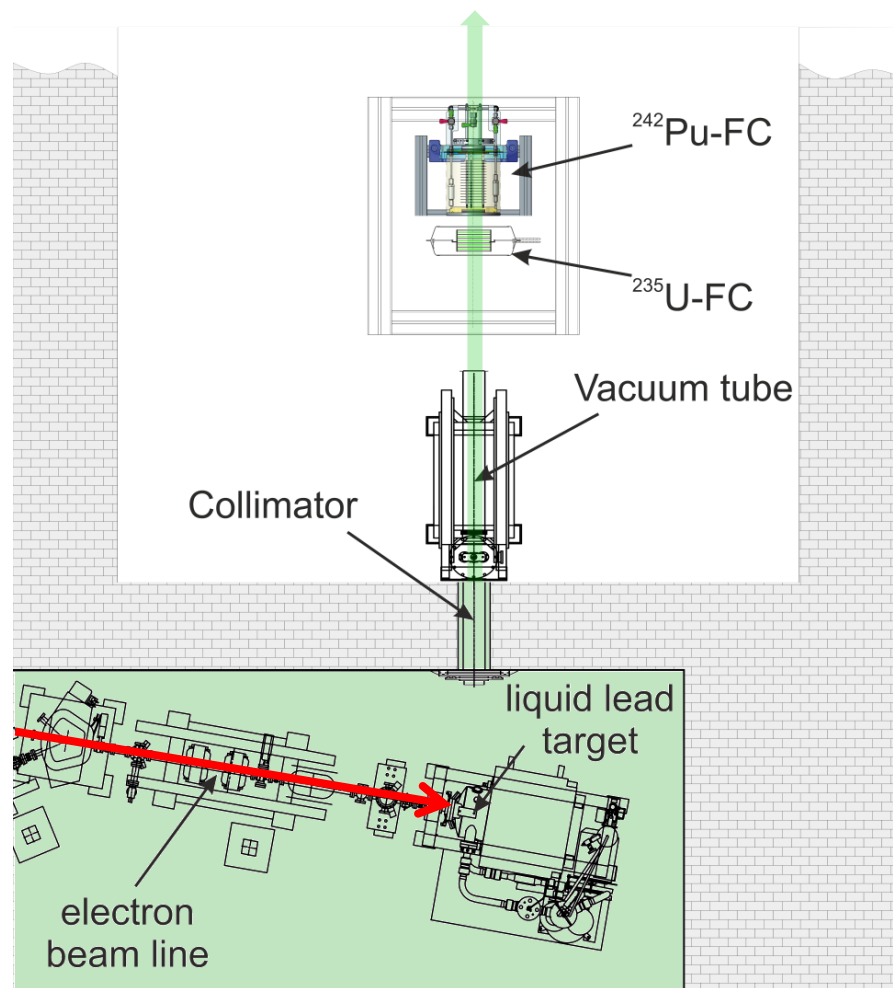
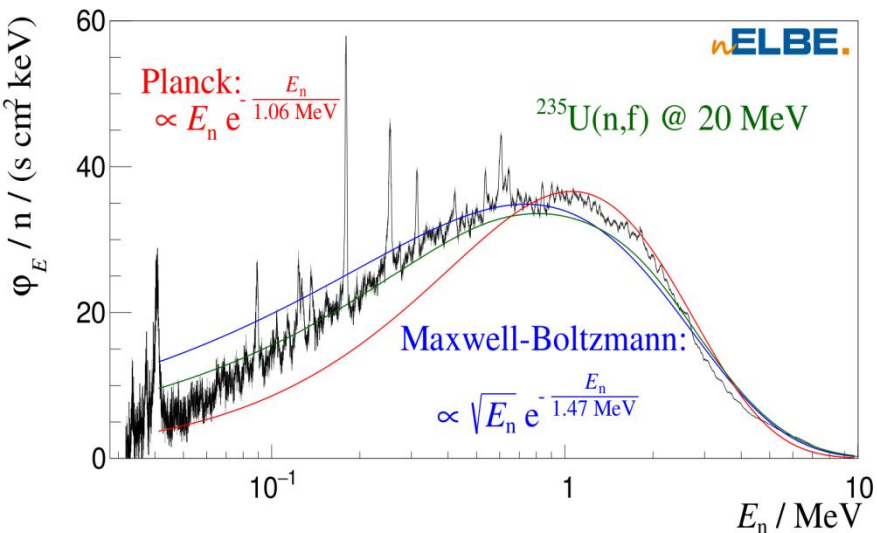

CHANDA SOLVING CHALLENGES IN NUCLEAR DATA FOR THE SAFETY OF EUROPEAN NUCLEAR FACILITIES SEVENTH FRAMEWORK PROGRAMME

Construction of a fission chamber

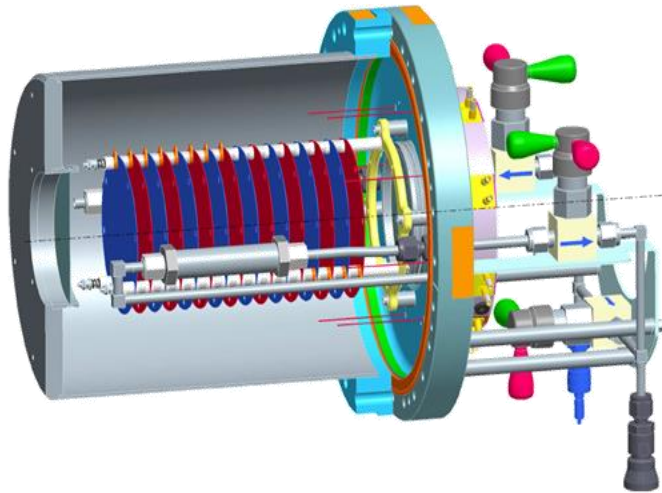

- parallel plate ionization chamber
- metal sealed housing (^{235}U and ^{242}Pu)
- continuous P10 gas flow with ultra efficient gas filters
- α -activity of $\approx 8.2 \text{ MBq}$ distributed on 8 channels (Sep. 2016)
→ separate readout necessary
- fast pre-amplifier (in-house development HZDR)

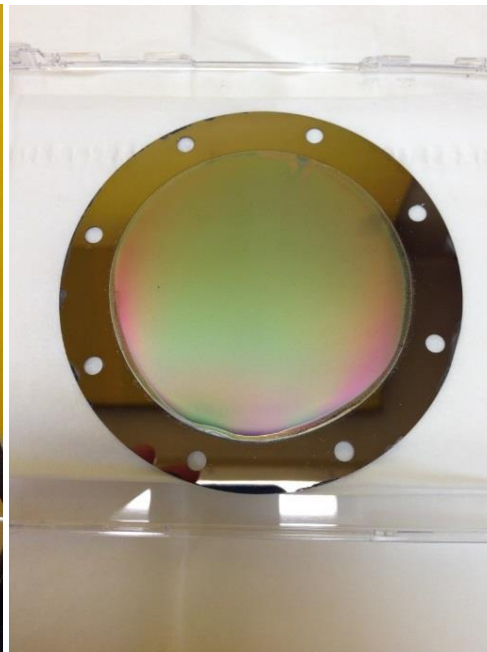
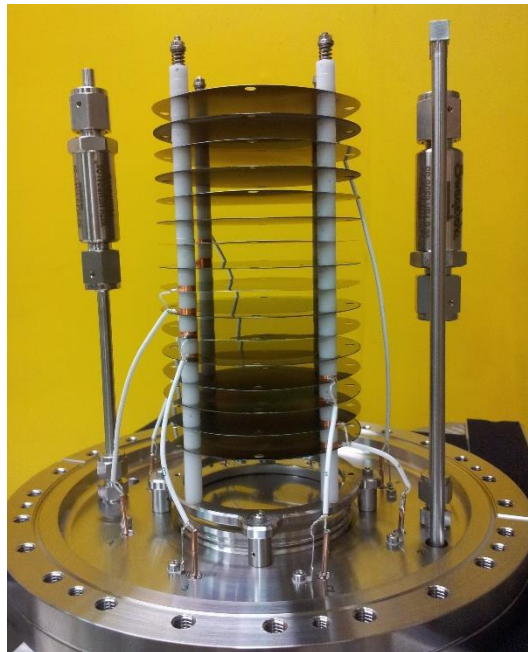

^{242}Pu deposit^[4], $\varnothing 74 \text{ mm}$,
 $m_{\text{tot}} \approx 37,24(22) \text{ mg}$, $\langle m_A \rangle \approx 108(4) \mu\text{g}/\text{cm}^2$
 Institute of Nuclear Chemistry, Mainz

[4] A. Vascon et al., Quantitative molecular plating of large-area ^{242}Pu targets with improved layer properties. *Appl. Radiat. Isot.* **95**, 36-43 (2015).

Fast pre-amplifier

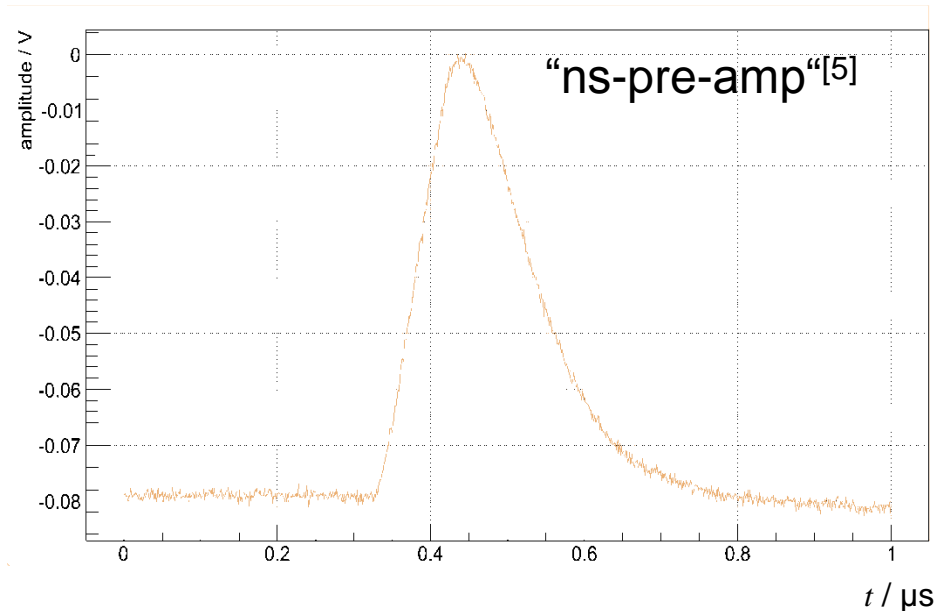
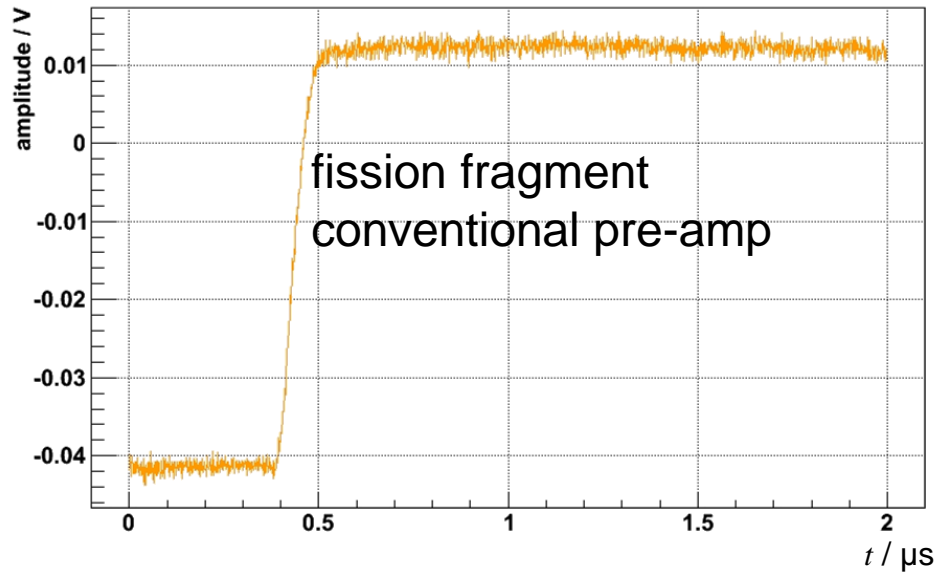

- parallel plate ionization chamber
- metal sealed housing (^{235}U and ^{242}Pu)
- continuous P10 gas flow with ultra efficient gas filters
- α -activity of $\approx 8.2 \text{ MBq}$ distributed on 8 channels (Sep. 2016)
→ separate readout necessary
- fast pre-amplifier (in-house development HZDR)
→ reduction of pulse pile-up
- time resolution: 1.7 ns

[5] K. Heidel. Charge Sensitive Preamplifier (CSP), *Tech. report* (2014)
<http://www.hzdr.de/db/Cms?pOid=39843>

Electronic

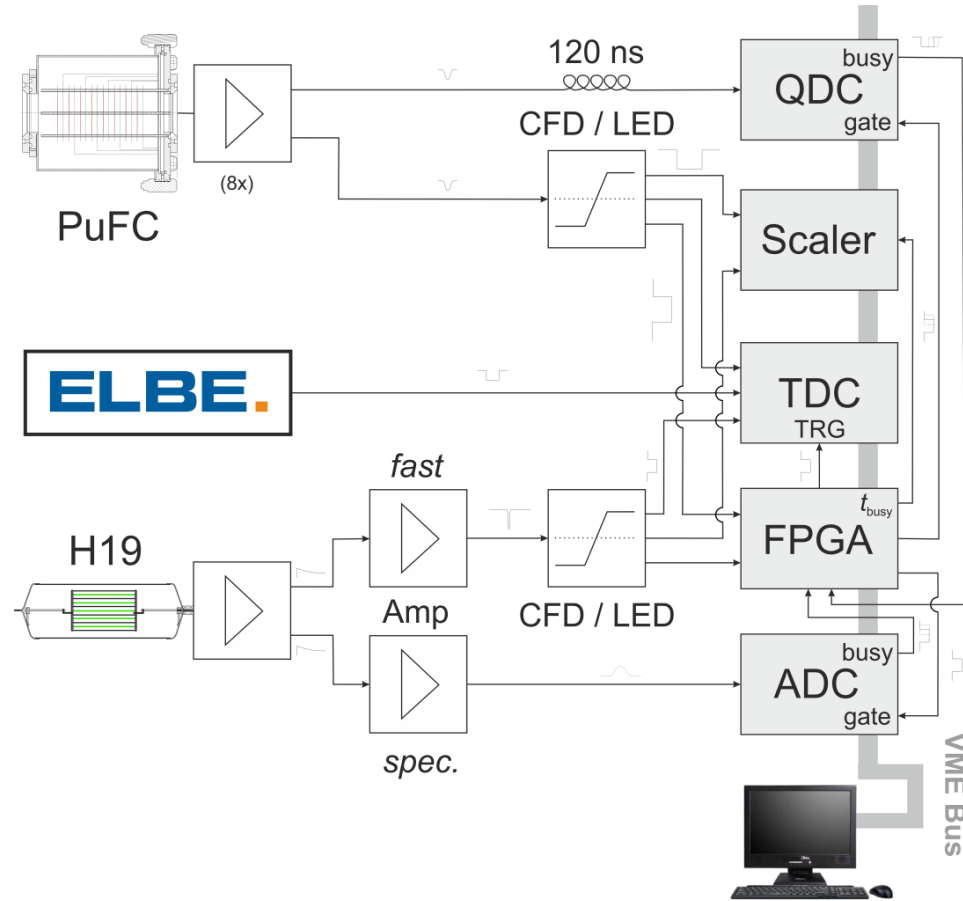
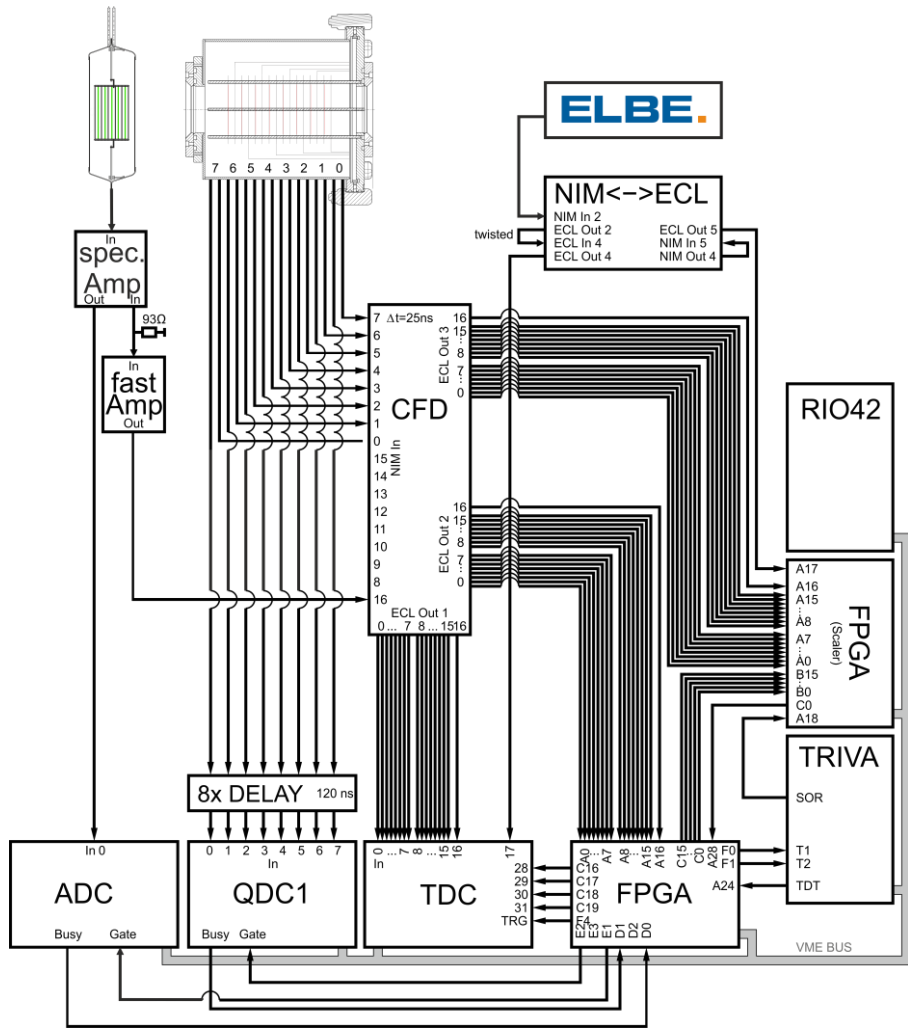

T. Kögler et al., *Phys. Proc.* 64 (2015)

Neutron Scattering Corrections

Geant4

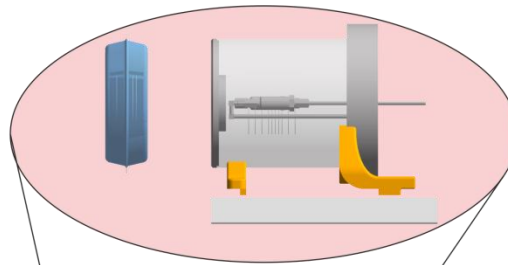

MCNP6

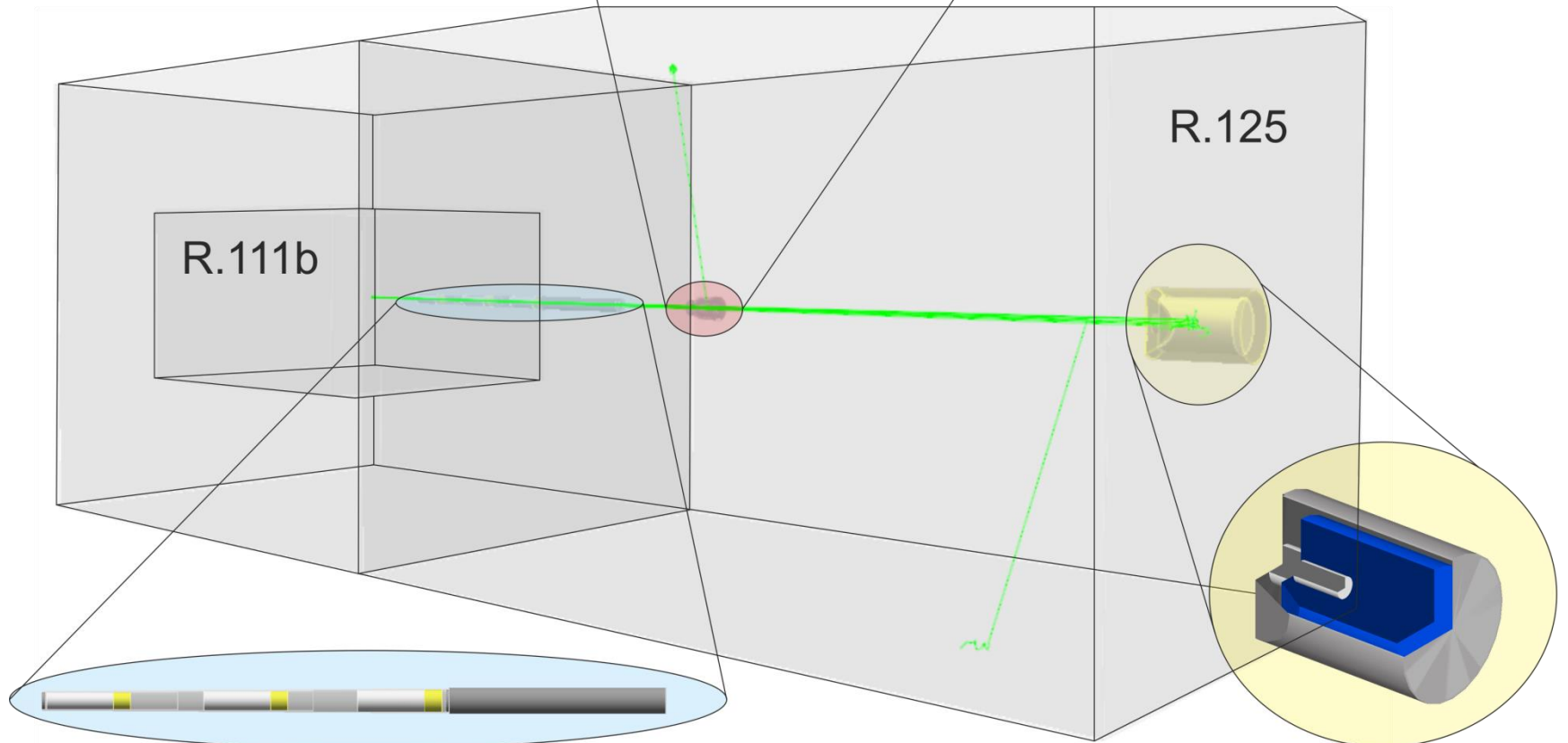

collimator with PE and Pb insets
beam tube

steel beam dump with
Pb, Cd and PE inset

Correction of the neutron fluence

Neutron transmission T

$$T^i(E) = \frac{\int N^i(E' = E(t))dE'}{\int N^0(E' = E(t))dE'}$$

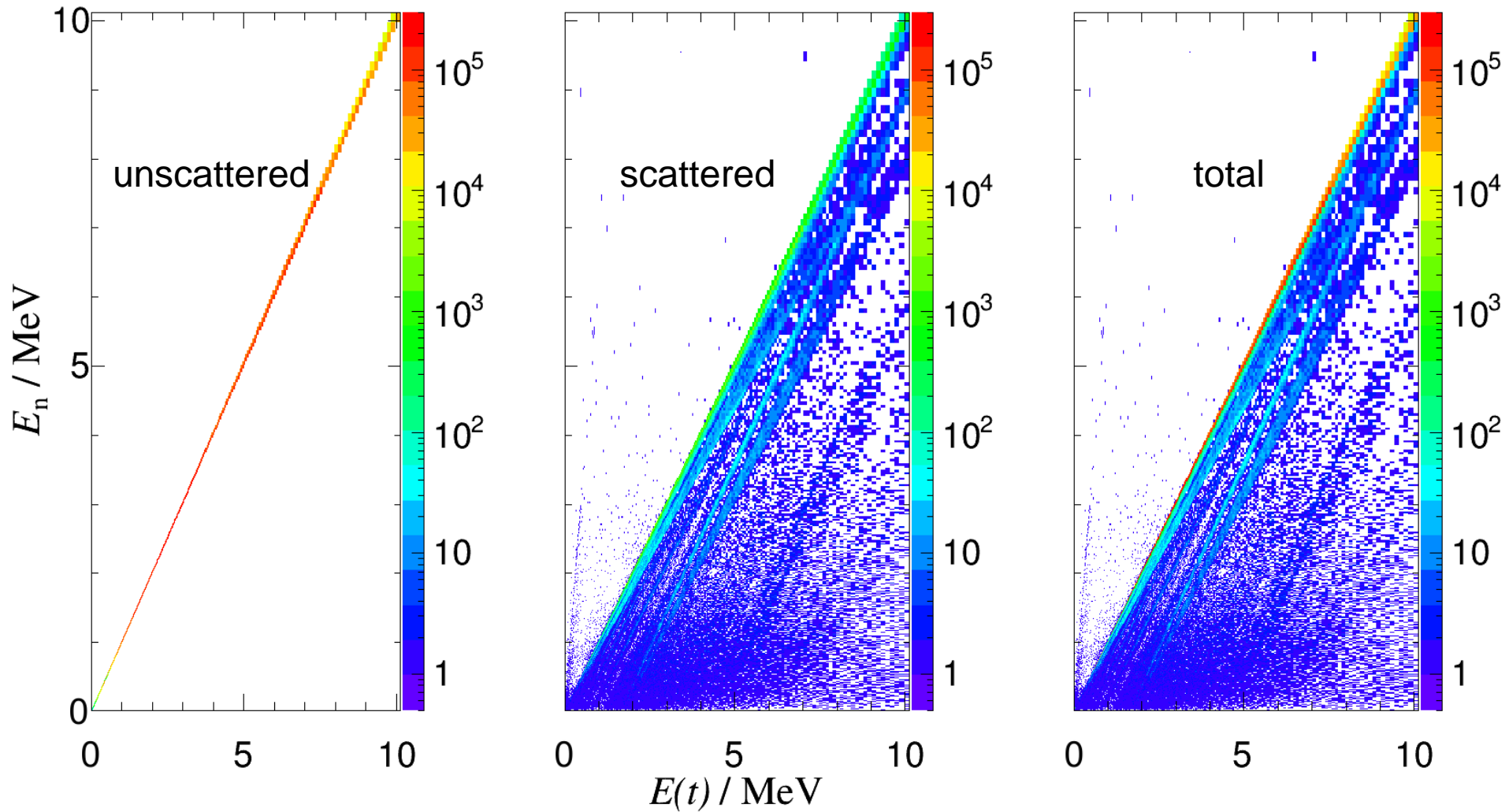

Correction of the neutron fluence

Correlation loss k

$$k^i(E(t)) = \frac{\int N^i(E' = E(t))\sigma_{(n,f)}(E')dE'}{\int N^i(E', E(t))\sigma_{(n,f)}(E')dE'}$$

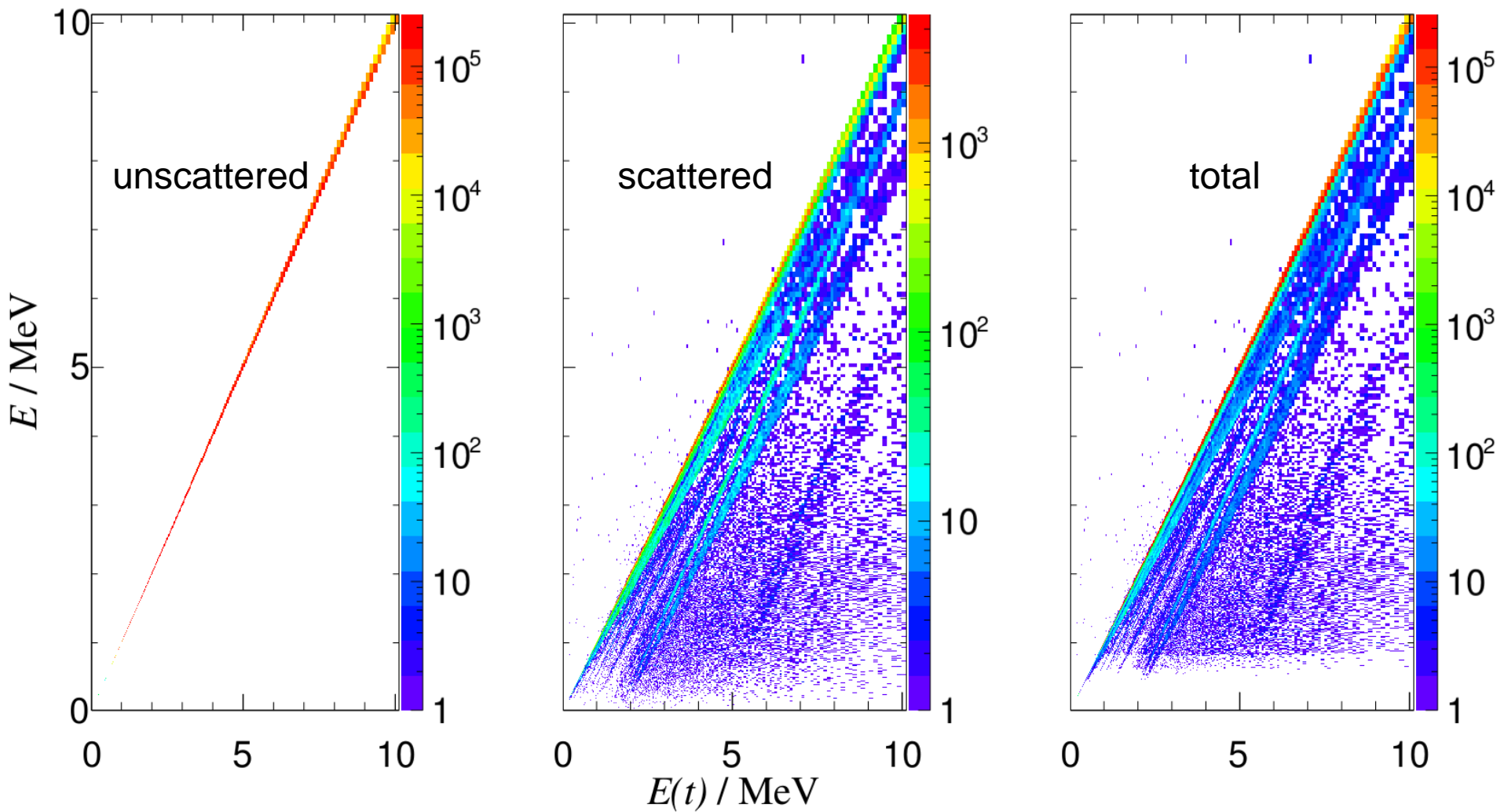

Neutron Transport Simulations

Correction factor C MCNP 6 vs. Geant 4

$$C^i = \frac{\alpha \cdot k^i}{T^i}$$

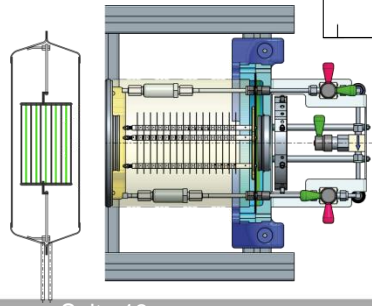
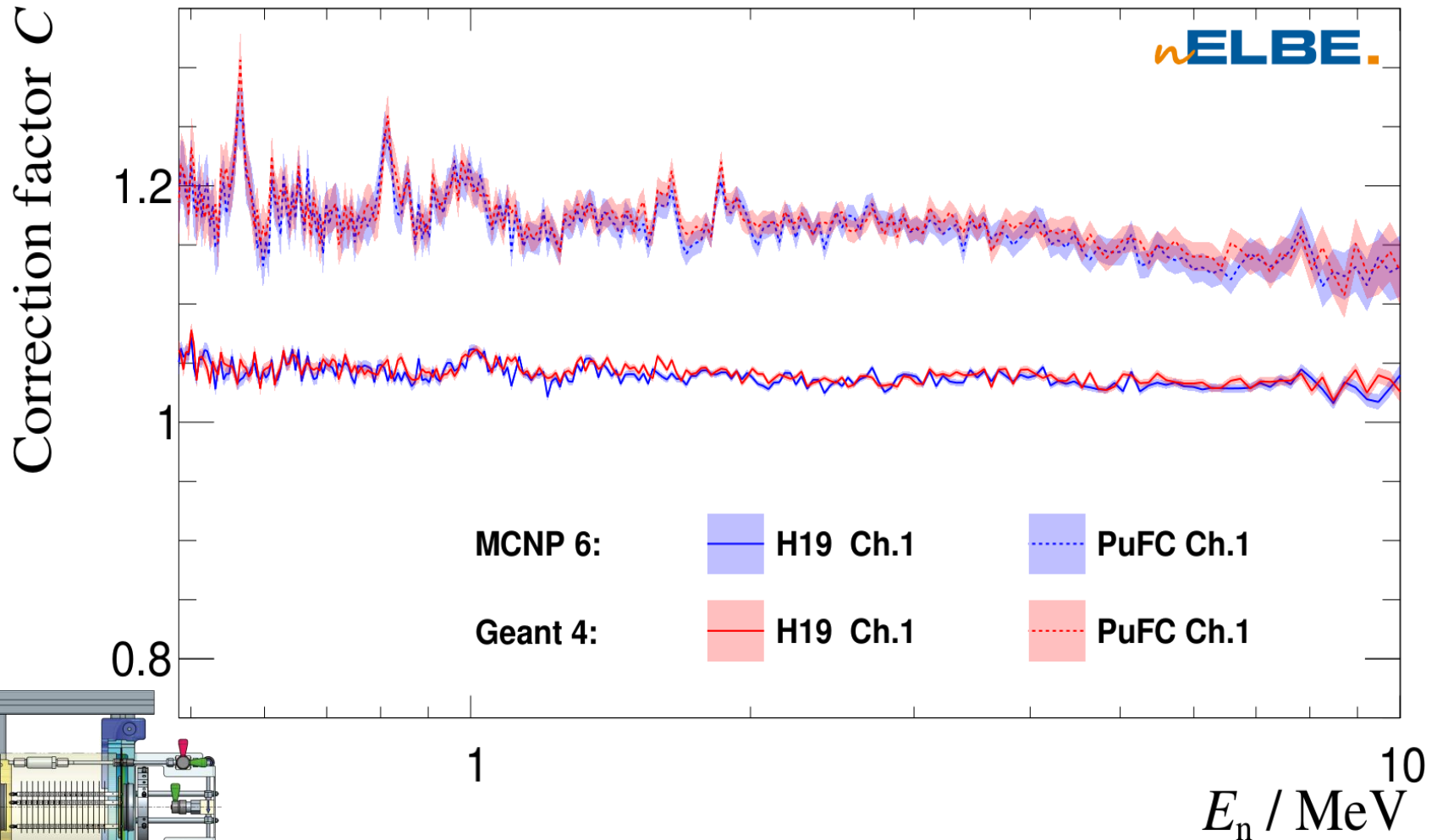

Absolute $^{242}\text{Pu}(n,f)$ reaction cross section

2 ns time-of-flight binning

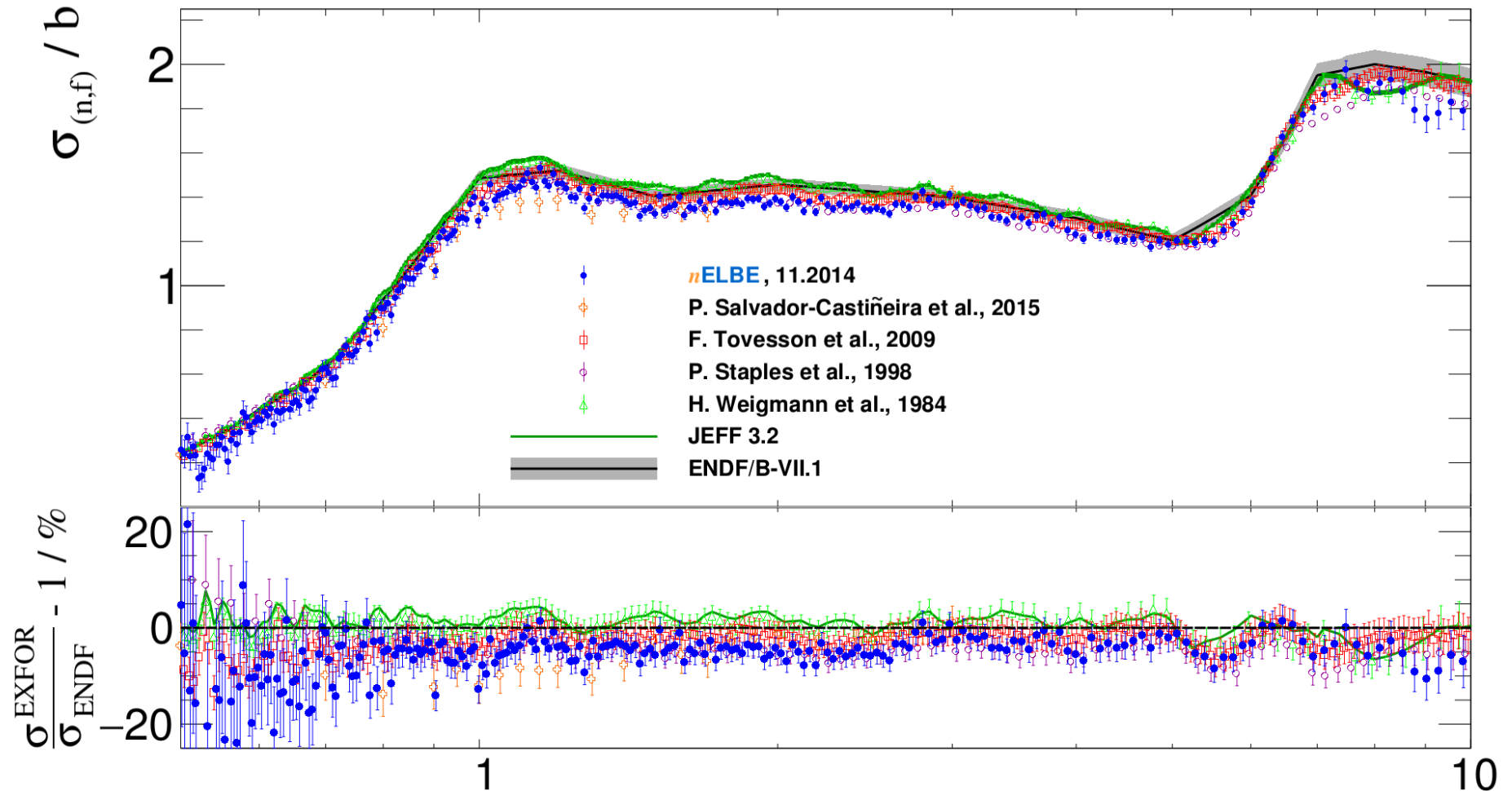

$$\langle \sigma_{\text{stat}} \rangle = 4.9 \% (1.1 \% - 47.4 \%)$$

$$\langle \sigma_{\text{sys}} \rangle = 3.8 \%$$